

Vacuum Relief Valve deflagration-proof

PROTEGO® SV/E

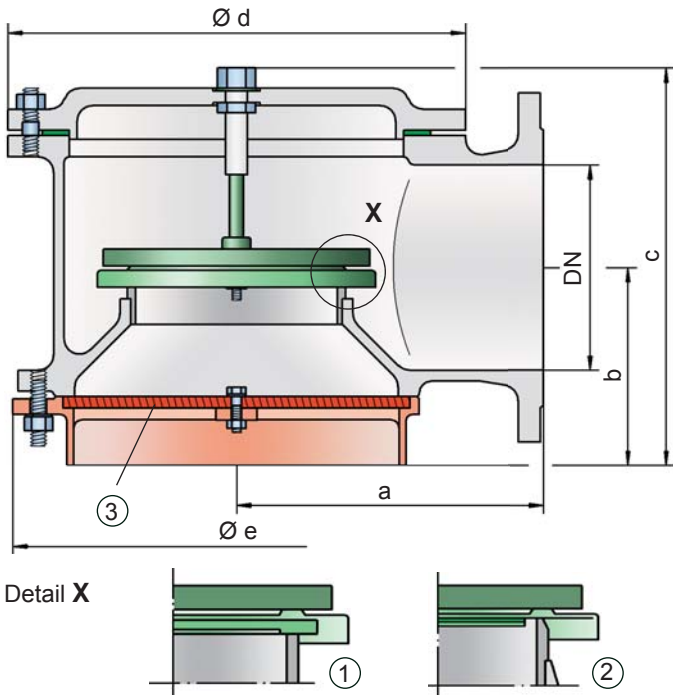

Vacuum settings:

-2.0 mbar up to -60 mbar (-0.2 kPa up to -6 kPa)
-0.8 inch W.C. up to -24 inch W.C.
Higher vacuum settings upon request

Function and Description

The deflagration-proof SV/E type PROTEGO® valve is a state of the art vacuum relief valve with an integrated flame arrester unit. It is primarily used as a safety device for flame transmission proof inbreathing on tanks, containers and process engineering apparatus. The valve offers reliable protection against vacuum and prevents inbreathing of air almost up to the set pressure; it also protects against atmospheric deflagration. The PROTEGO® flame arrester unit is designed to achieve minimum pressure drop with maximum safety. The PROTEGO® SV/E valve is available for substances from explosion groups IIA to IIC.

When the set vacuum is reached, the valve starts to open and reaches full lift within 10% overpressure. This unique 10% technology enables a set vacuum that is only 10% above the maximum allowable working vacuum (MAWV) of the tank. After years of development, this typical opening characteristic of a safety relief valve is now also available for the low pressure range.

The tank pressure is maintained up to the set vacuum with a tightness that is far superior to the conventional standard due to our state of the art manufacturing technology. This feature is ensured by the valve seats made of high quality stainless steel and with individually lapped valve pallets (1) or with an air cushion seal (2) in conjunction with high quality FEP diaphragm. The valve pallets are also available with a PTFE seal to prevent the valve pallets from sticking when sticky products are used and to enable the use of corrosive fluids. After the vacuum is equalized, the valve reseats and provides a tight seal.

If the valve is used in atmospheres forming an explosive mixture with air and the mixture ignites, the integrated PROTEGO® flame arrester unit (3) prevents flame transmission into the tank.

The standard design is tested at an operating temperature up to +60°C / 140°F and meets the requirements of European tank design standard EN 14015 – Appendix L and ISO 28300 (API 2000). In addition numerous versions for higher operating temperature are available.

Type-approved in accordance with the current ATEX Directive and EN ISO 16852 as well as other international standards. Additional certificates from classification associations for use on ships are also available.

Special Features and Advantages

- requires only 10% overpressure to full lift
- extreme tightness and hence least possible product losses and reduced environmental pollution
- through 10% technology lower set vacuum can be reached which results in product loss reduction compared to conventional 40% and 100% overpressure technology vents (compare API 2000)
- optimized flow performance
- the valve disc is guided within the housing to protect against harsh weather conditions
- can be used as protective system according ATEX in areas subject to explosion hazards
- FLAMEFILTER® provides protection against atmospheric deflagration
- FLAMEFILTER® integrated into the valve saves space, weight and reduces cost
- FLAMEFILTER® protected from clogging through product vapour
- PROTEGO® flame arrester unit has a low pressure drop
- maintenance friendly design
- modular design enables individual FLAMEFILTER® and valve pallets to be replaced
- an additional lifting gear can be purchased

Design Types and Specifications

The valve disc is weight-loaded. **Higher vacuum can be achieved upon request with a special spring loaded design.**

There are four different designs:

Vacuum relief valve, basic design	SV/E-[-]-[-]
Vacuum relief valve with heating jacket (max. heating fluid temperature +85°C / 185°F)	SV/E-[-]-[H]
Vacuum relief valve with lifting gear (ship design)	SV/E-[S]-[-]
Vacuum relief valve with lifting gear (ship design) and heating jacket (max. heating fluid temperature +85°C / 185°F)	SV/E-[S]-[H]

Additional special devices available upon request



Vents - 10% Technology
(Flyer pdf)



Leak Rate/10% Technology
(Flyer pdf)

Table 1: Dimensions

Dimensions in mm / inches

To select the nominal size (DN), please use the flow capacity chart on the following page

DN	50 / 2"	80 / 3"	100 / 4"	150 / 6"	200 / 8"	250 / 10"	300 / 12"
a	140 / 5.51	170 / 6.69	190 / 7.48	230 / 9.06	300 / 11.81	325 / 12.80	425 / 16.73
b	105 / 4.13	115 / 4.53	125 / 4.92	165 / 6.50	195 / 7.68	230 / 9.06	280 / 11.02
c	225 / 8.86	240 / 9.45	320 / 12.60	410 / 16.14	460 / 18.11	525 / 20.67	575 / 22.64
d	170 / 6.69	235 / 9.25	280 / 11.02	335 / 13.19	445 / 17.52	505 / 19.88	505 / 19.88
e	215 / 8.46	215 / 8.46	255 / 10.04	345 / 13.58	435 / 17.13	470 / 18.50	635 / 25.00

Table 2: Selection of explosion group

MESG	Expl. Gr. (IEC/CEN)	Gas Group (NEC)	
≥ 0,65 mm	IIB3	C	Special approvals upon request
≥ 0,5 mm	IIB	B	
□ 0,5 mm	IIC	B	

Table 3: Specification of max. operating temperature

≤ 60°C / 140°F	Tmaximum allowable operating temperature in °C	
-	Designation	higher operating temperatures upon request

Table 4: Material selection for housing

Design	B	C	
Housing	Steel	Stainless Steel	Special materials upon request
Heating jacket (SV/E-(S)-H-...)	Steel	Stainless Steel	
Valve seat	Stainless Steel	Stainless Steel	
Gasket	PTFE	PTFE	
Flame arrester unit	B	B	

Table 5: Material combinations of flame arrester unit

Design	B	
FLAMEFILTER® cage	Stainless Steel	Special materials upon request
FLAMEFILTER®	Stainless Steel	

Table 6: Material selection for valve pallet

Design	A	B	C	D	E	F
Vacuum range (mbar) (inch W.C.)	-2.0 up to -3.5 -0.8 up to -1.4	<-3.5 up to -14 <-1.4 up to -5.6	<-14 up to -35 <-5.6 up to -14	<-35 up to -60 <-14 up to -24	<-14 up to -35 <-5.6 up to -14	<-35 up to -60 <-14 up to -24
Valve pallet	Aluminium	Stainless Steel	Stainless Steel	Stainless Steel	Stainless Steel	Stainless Steel
Sealing	FEP	FEP	Metal to Metal	Metal to Metal	PTFE	PTFE

Special materials and higher pressure settings upon request

Table 7: Flange connection type

EN 1092-1; Form B1	other types upon request
ASME B16.5; 150 lbs RFSF	



for safety and environment

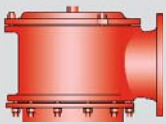

Vacuum Relief Valve

Flow Capacity Chart

PROTEGO® SV/E

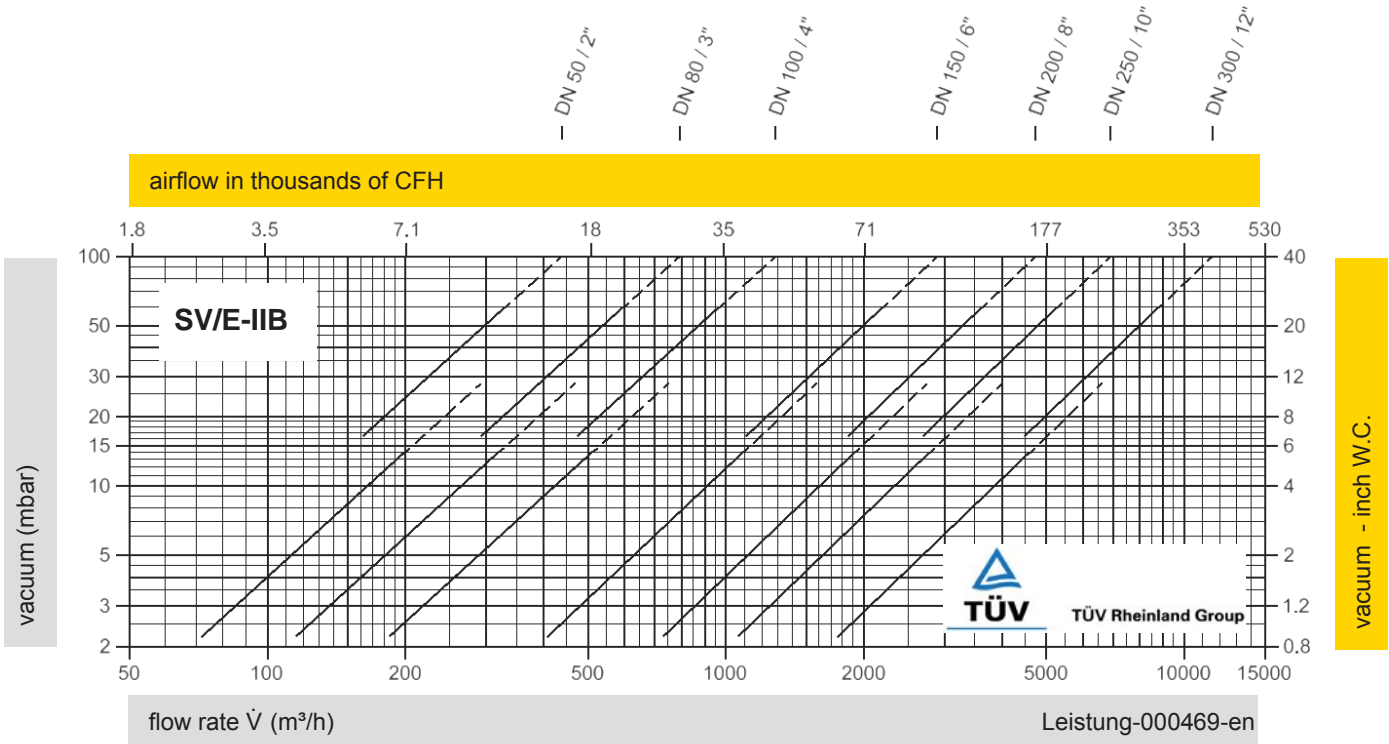
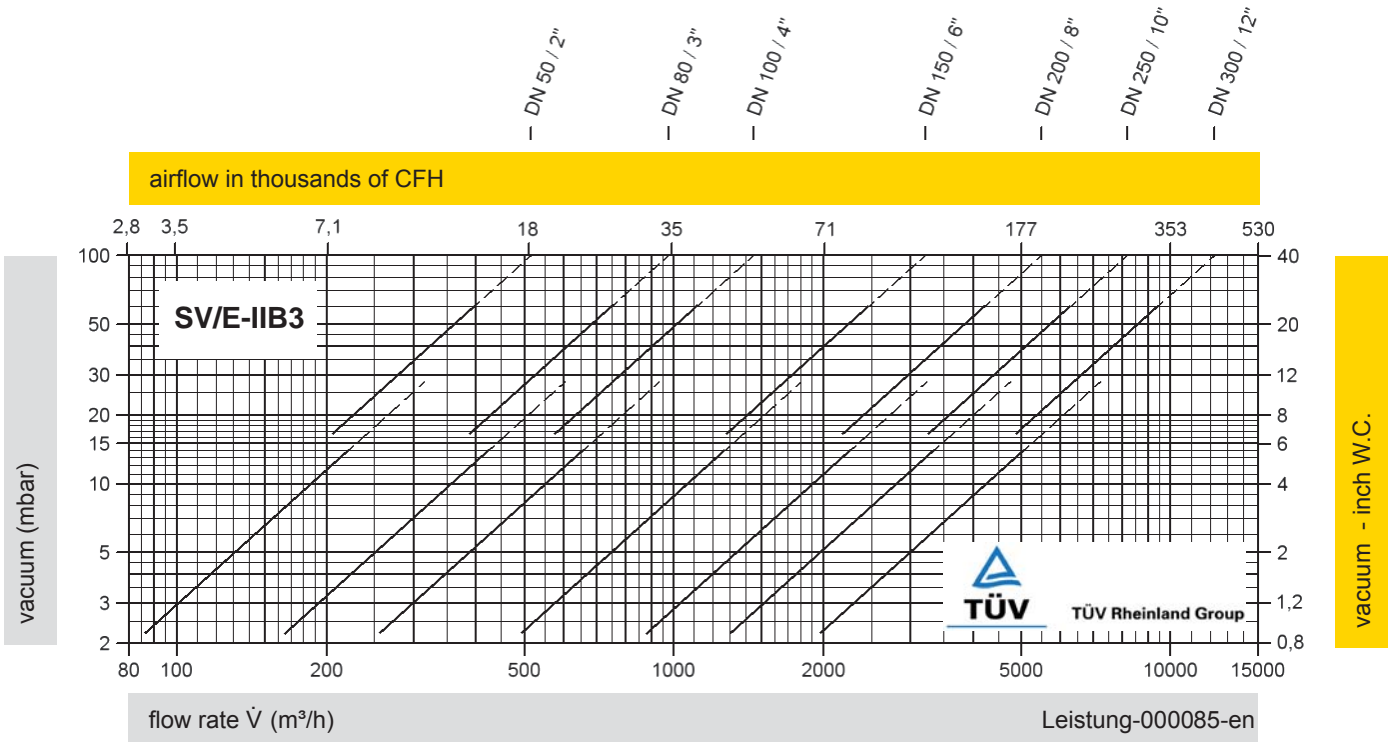

The flow capacity charts have been determined with a calibrated and TÜV certified flow capacity test rig. Volume flow \dot{V} in (m³/h) and CFH refer to the standard reference conditions of air ISO 6358 (20°C, 1bar). Conversion to other densities and temperatures refer to Vol. 1: "Technical Fundamentals".

