

Pressure Relief Valve

PROTEGO® ER/VH

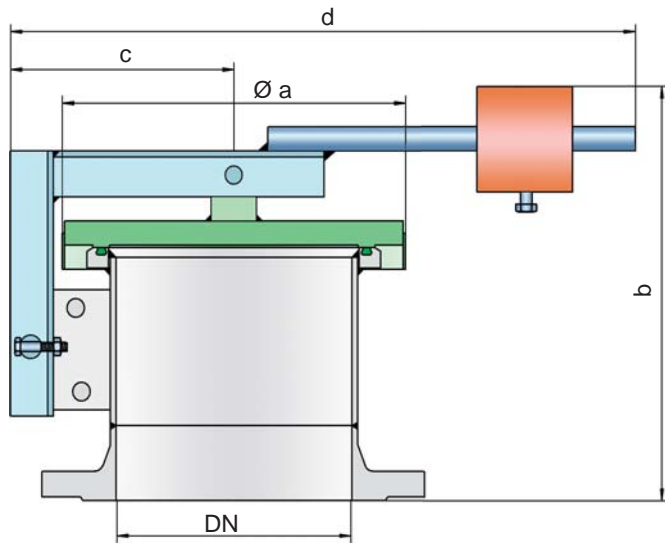

Pressure settings:

DN 200 to DN 350: >+40 mbar up to +60 mbar
>+16 inch W.C. up to +24 inch W.C.
DN 400 to DN 700: >+25 mbar up to +60 mbar
>+10 inch W.C. up to +24 inch W.C.

Higher and lower pressure settings, upon request.

Function and Description

The ER/VH type PROTEGO® valve is a highly developed emergency pressure relief valve with high flow capacity. It is primarily used as a safety device for emergency pressure relief for storage tanks, containers, silos, and process engineering equipment; it offers reliable protection against overpressure and prevents impermissible product vapor loss close to the set pressure. It is designed to discharge particularly large amounts to prevent the vessel from rupturing in an emergency case. Higher set pressures are achieved by a lever with lockable weight loading. The position of the weight is factory-marked. Starting at DN 500, the devices can also be used as manhole covers.

When the set pressure is reached, the valve starts to open and is fully open within 10% overpressure. This unique 10% "full lift type technology" enables a pressure setting that is only 10% below the maximum allowable working pressure or design pres-

sure of the tank. Even in the low pressure range the vent has the opening characteristic comparable to a typical high pressure safety relief valve. The full lift type pallets are a result of many years of development. The valve pallet is mounted on one side.

Due to the highly developed manufacturing technology, the tank pressure is maintained up to the set pressure, with a tightness that is far superior to the conventional standard. This feature is achieved by valve seats made of stainless steel with an inserted O-ring seal, a precisely lapped valve pallet, as well as a reinforced housing design. After the excess pressure is discharged, the valve reseats and provides a tight seal again.

Special Features and Advantages

- "full lift type" technology valve utilizes only 10% overpressure to reach full lift
- excellent tightness and hence least possible product losses and reduced environmental pollution
- the set pressure is close to the opening pressure which results in best possible pressure management of the system
- high flow capacity
- can be used in areas subject to explosion hazards
- reinforced housing design
- safely secured housing cover
- best technology for API-tanks

Design Types and Specifications

The valve pallet is weight-loaded. Lower pressures are generally achieved without a lever design (see ER-V-LP, ER/V), and higher pressures are realized with spring-loading (see ER/V-F).

Pressure valve in basic design

ER/VH

Additional special devices available upon request



Table 1: Dimensions Dimensions in mm / inches

To select the nominal size (DN), use the flow capacity chart on the following page

DN	200 / 8"	250 / 10"	300 / 12"	350 / 14"	400 / 16"	450 / 18"	500 / 20"	600 / 24"	700 / 28"
a	305 / 12.01	375 / 14.76	425 / 16.73	445 / 17.52	495 / 19.49	545 / 21.46	615 / 24.21	715 / 28.15	795 / 31.30
b	350 / 13.78	365 / 14.37	385 / 15.16	390 / 15.35	390 / 15.35	415 / 16.34	430 / 16.93	450 / 17.72	465 / 18.31
c	200 / 7.87	240 / 9.45	265 / 10.43	285 / 11.22	310 / 12.20	330 / 12.99	360 / 14.17	410 / 16.14	450 / 17.72
d	590 / 23.23	735 / 28.94	780 / 30.71	845 / 33.27	890 / 35.04	1070 / 42.13	1090 / 42.91	1140 / 44.88	1380 / 54.33

Table 2: Material selection

Design	A	B
Housing	Steel	Stainless Steel
Valve seat	Stainless Steel	Stainless Steel
Valve pallet	Stainless Steel or Steel-Stainless Steel	Stainless Steel
Sealing	FPM	FPM
Weight	Steel	Stainless Steel

Special materials upon request

Table 3: Flange connection type

EN 1092-1; Form B1	other types upon request
ASME B16.5; 150 lbs RFSF	

Flow Capacity Chart

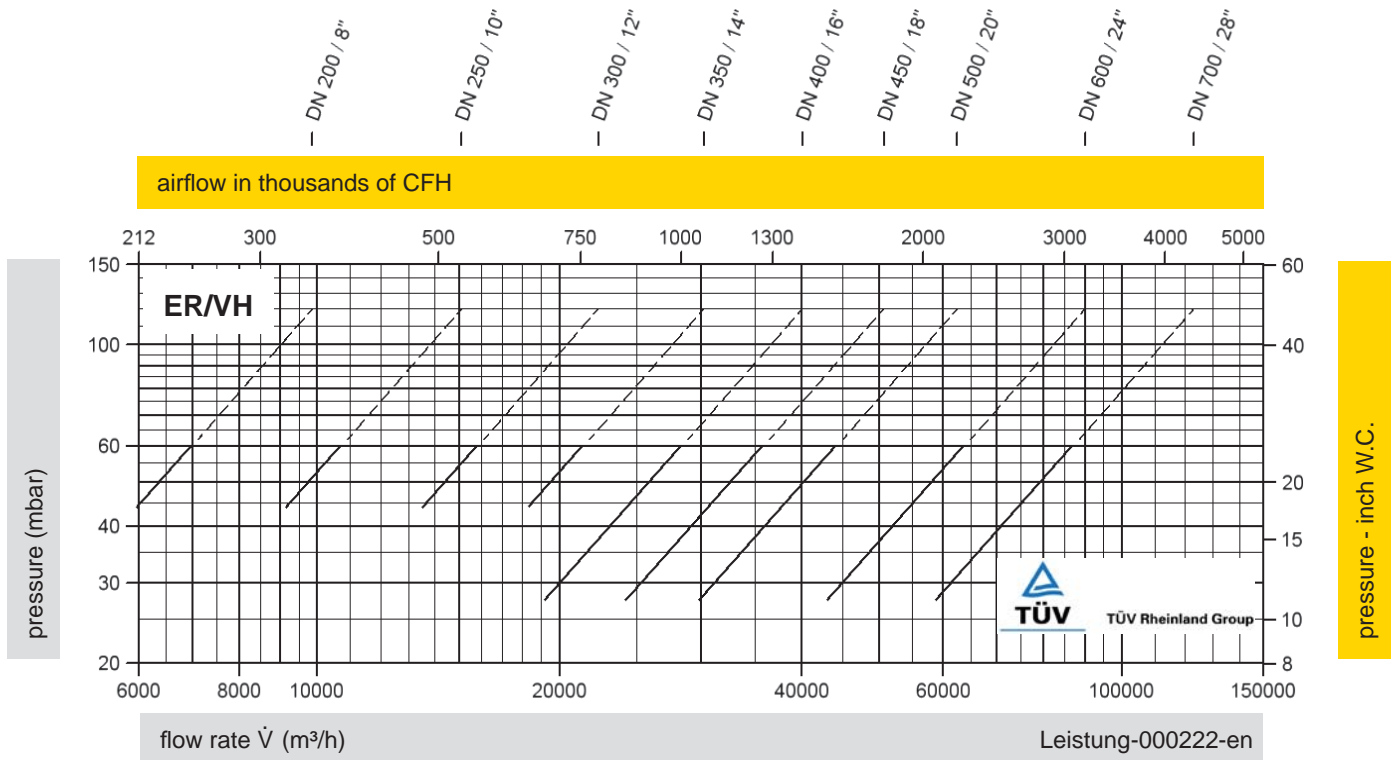

The flow capacity chart has been determined with a calibrated and TÜV certified flow capacity test rig. Volume flow \dot{V} in (m^3/h) and CFH refer to the standard reference conditions of air ISO 6358 (20°C, 1bar). Conversion to other densities and temperatures refer to Vol. 1: "Technical Fundamentals".

