

Vacuum Relief Valve

Deflagration-proof

PROTEGO® SV/E

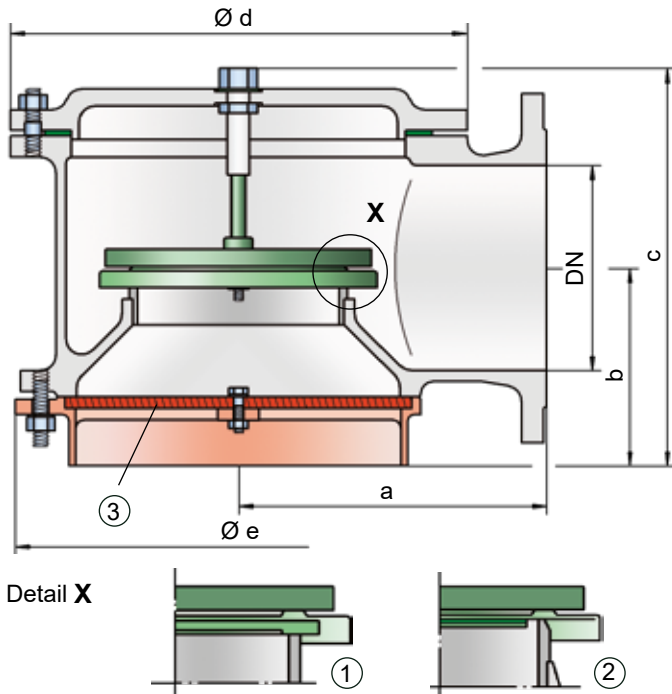

Vacuum settings:

-2.0 mbar up to -60 mbar (-0.2 kPa up to -6 kPa)

-0.8 inch W.C. up to -24 inch W.C.

Higher vacuum settings upon request.

Function and Description

The deflagration-proof SV/E type PROTEGO® valve is a state-of-the-art vacuum relief valve with an integrated flame arrester unit. It is primarily used as a safety device for flame transmission-proof in-breathing on tanks, containers, and process equipment. The valve offers reliable protection against vacuum and prevents in-breathing of air almost up to the set pressure; while at the same time protecting against atmospheric deflagration. The PROTEGO® flame arrester unit is designed to achieve minimum pressure drop with maximum safety. The PROTEGO® SV/E valve is available for substances from explosion groups IIA to IIC.

When the set vacuum is reached, the valve starts to open and reaches full lift within 10% overpressure. This unique 10% technology enables a set vacuum that is only 10% above the maximum allowable working vacuum (MAWV) of the tank. After years of development, this typical opening characteristic of a safety relief valve is now also available for the low pressure range.

The tank pressure is maintained up to the set vacuum with a tightness that is above the normal standards due to our state-of-the-art manufacturing technology. This feature is ensured by the valve seats made of high quality stainless steel and with individually lapped valve pallets (1), or with an air cushion seal, (2) in conjunction with high quality FEP diaphragm. The valve pallets are also available with a PTFE seal to prevent them from sticking when sticky substances are used and to enable the use of corrosive fluids. After the vacuum is balanced, the valve re-seats and provides a tight seal.

If the valve is used in atmospheres forming an explosive mixture with air and the mixture ignites, the integrated PROTEGO® flame arrester unit (3) prevents flame transmission into the tank.

The standard design is tested at an operating temperature of up to +60°C / 140°F and meets the requirements of European tank design standard EN 14015 (Appendix L) and ISO 28300 (API 2000). In addition, numerous versions for higher operating temperature are available.

Type-approved in accordance with the current ATEX Directive and EN ISO 16852, as well as other international standards. Additional certificates from classification organizations for use on ships are also available.

Special Features and Advantages

- 10% technology for minimum pressure increase up to full lift
- excellent tightness, resulting in lowest possible product losses and reduced environmental pollution
- due to 10% technology, set pressure is close to opening pressure for optimum pressure maintenance in the system as compared to conventional 40% or 100% technology
- high flow capacity
- valve pallet is guided inside the housing to protect against harsh weather conditions
- can be used as a protective system in areas with potentially explosive atmospheres in accordance with ATEX
- FLAMEFILTER® provides protection against atmospheric deflagrations
- integrated FLAMEFILTER® saves space and weight and reduces costs
- FLAMEFILTER® is protected from clogging and sticky substances caused by product vapors
- minimum pressure loss of the PROTEGO® flame arrester unit
- maintenance-friendly design
- modular design enables replacement of individual FLAMEFILTER® discs and valve pallet
- available in a special design with lifting device (for ships)

Design Types and Specifications

The valve pallet is weight-loaded. **Higher vacuum can be achieved upon request, with a special spring loaded design.**

There are four different designs:

Vacuum relief valve, basic design SV/E-[-]-[-]

Vacuum relief valve with heating jacket (max. heating fluid temperature +85°C / 185°F) SV/E-[-]-[H]

Vacuum relief valve with lifting gear (ship design) SV/E-[S]-[-]

Vacuum relief valve with lifting gear (ship design) and heating jacket (max. heating fluid temperature +85°C / 185°F) SV/E-[S]-[H]

Additional special devices available upon request.



Vents - 10% Technology
(Flyer pdf)



Leak Rate/10% Technology
(Flyer pdf)

Table 1: Dimensions

Dimensions in mm / inches

To select the nominal size (DN), please use the flow capacity chart on the following page.

DN	50 / 2"	80 / 3"	100 / 4"	150 / 6"	200 / 8"	250 / 10"	300 / 12"
a	140 / 5.51	170 / 6.69	190 / 7.48	230 / 9.06	300 / 11.81	325 / 12.80	425 / 16.73
b	105 / 4.13	115 / 4.53	125 / 4.92	165 / 6.50	195 / 7.68	230 / 9.06	280 / 11.02
c	225 / 8.86	240 / 9.45	320 / 12.60	410 / 16.14	460 / 18.11	525 / 20.67	575 / 22.64
d	170 / 6.69	235 / 9.25	280 / 11.02	335 / 13.19	445 / 17.52	505 / 19.88	505 / 19.88
e	215 / 8.46	215 / 8.46	255 / 10.04	345 / 13.58	435 / 17.13	470 / 18.50	635 / 25.00

Table 2: Selection of explosion group

MESG	Expl. Gr. (IEC/CEN)	Gas Group (NEC)	Special approvals upon request.
≥ 0,65 mm	IIB3	C	
≥ 0,5 mm	IIB	B	
< 0,5 mm	IIC	B	

Table 3: Specification of max. operating temperature

≤ 60°C / 140°F	Tmaximum allowable operating temperature in °C	Higher operating temperatures upon request.
-	Classification	

Table 4: Material selection for housing

Design	B	C	Special materials upon request.
Housing	Steel	Stainless Steel	
Heating jacket (SV/E-(S)-H-...)	Steel	Stainless Steel	
Valve seat	Stainless Steel	Stainless Steel	
Gasket	PTFE	PTFE	
Flame arrester unit	B	B	

Table 5: Material combinations of flame arrester unit

Design	B	Special materials upon request.
FLAMEFILTER® casing	Stainless Steel	
FLAMEFILTER®	Stainless Steel	

Table 6: Material selection for valve pallet

Design	A	B	C	D	E	F
Vacuum range (mbar) (inch W.C.)	-2.0 up to -3.5 -0.8 up to -1.4	<-3.5 up to -14 <-1.4 up to -5.6	<-14 up to -35 <-5.6 up to -14	<-35 up to -60 <-14 up to -24	<-14 up to -35 <-5.6 up to -14	<-35 up to -60 <-14 up to -24
Valve pallet	Aluminum	Stainless Steel	Stainless Steel	Stainless Steel	Stainless Steel	Stainless Steel
Sealing	FEP	FEP	Metal to Metal	Metal to Metal	PTFE	PTFE

Special materials and higher pressure settings upon request.

Table 7: Flange connection type

EN 1092-1; Form B1	Other types upon request.
ASME B16.5 CL 150 R.F.	



for safety and environment

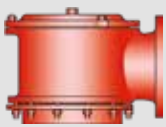

Vacuum Relief Valve

Flow Capacity Chart

PROTEGO® SV/E

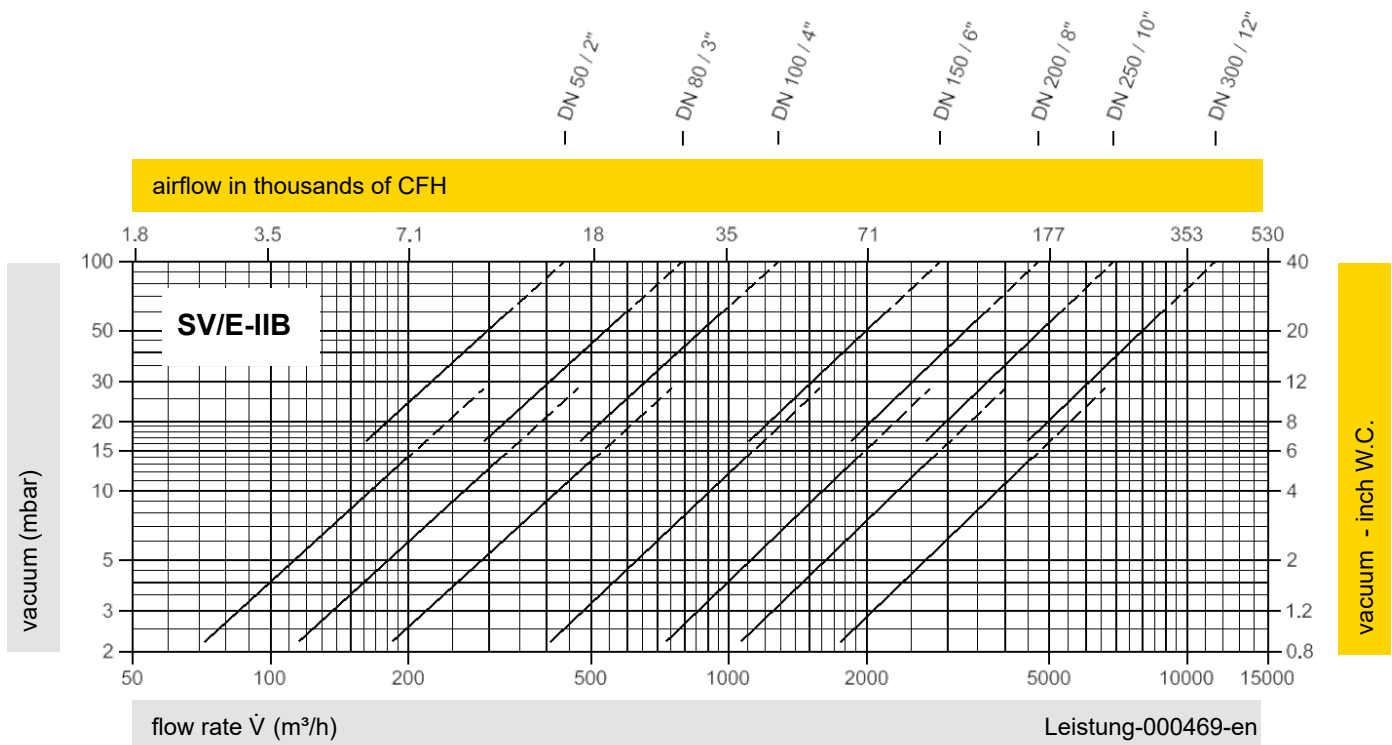
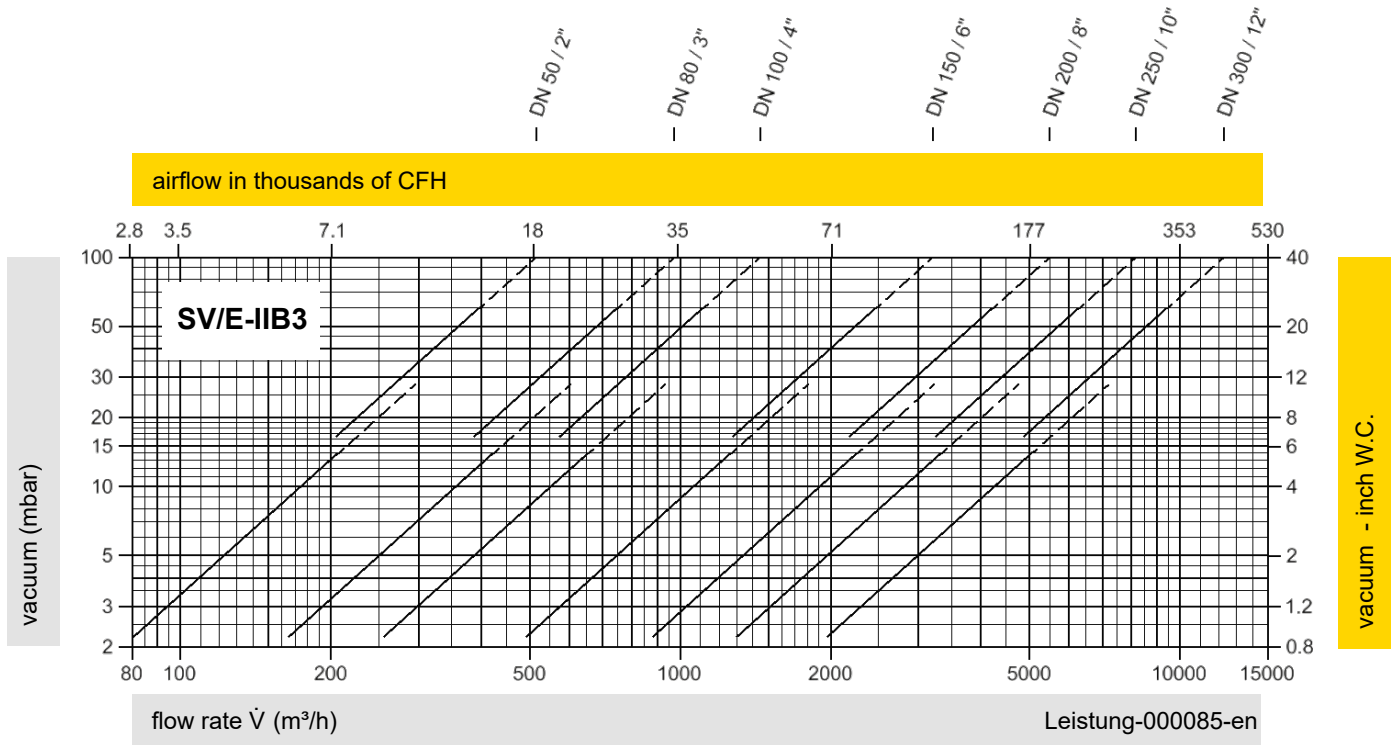

The flow capacity charts have been determined with a calibrated and TÜV certified flow capacity test rig. Volume flow \dot{V} in (m³/h) and CFH refer to the standard reference conditions of air in ISO 6358 (20°C, 1bar). For conversion to other densities and temperatures, refer to Sec. 1: "Technical Fundamentals."

