

Pressure Relief Valve

Deflagration-proof and Endurance Burning-proof

PROTEGO® P/EB-E

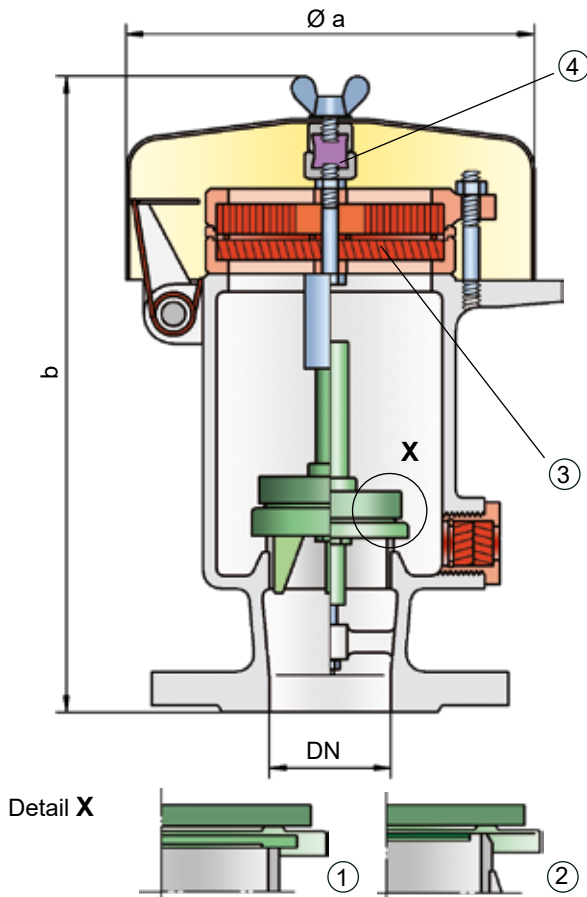

and with individually lapped valve pallets (1), or with an air cushion seal (2), in conjunction with high quality FEP diaphragm. The valve pallets are also available with a PTFE seal to prevent the valve pallets from sticking when sticky substances are used and to enable the use of corrosive fluids. After the overpressure is released, the valve re-seats and provides a tight seal.

If the set pressure is exceeded, explosive gas/product vapor/air mixtures are released into the atmosphere. If this mixture ignites, the integrated PROTEGO® flame arrester unit (3) prevents flame transmission to the tank. If additional mixture continues to flow and stabilized burning occurs, the integrated flame arrester unit prevents flashback as a result of endurance burning. The valve is protected and also fulfils its function under these severe conditions. The spring-loaded weather hood opens as soon as the melting element (4) melts.

The valve can be used up to an operating temperature of up to +60°C / 140°F and meets the requirements of European tank design standard EN 14015 (Appendix L) and ISO 28300 (API 2000).

Type-approved in accordance with the current ATEX Directive and EN ISO 16852, as well as other international standards

Special Features and Advantages

- extreme tightness, resulting in lowest possible product losses and reduced environmental pollution
- set pressure close to opening pressure for optimum pressure maintenance in the system
- valve opens later and closes earlier than conventional valves
- valve pallet is guided inside the housing to protect against harsh weather conditions
- can be used as protective system according in areas with potentially explosive atmospheres in accordance with ATEX
- protected against deflagration and endurance burning of alcohol/air mixtures from explosion group IIB1
- PROTEGO® flame arrester unit provides protection against atmospheric deflagrations and endurance burning
- integrated PROTEGO® flame arrester unit saves space and weight and reduces costs
- flame arrester unit is protected from clogging and sticky substances caused by product vapors
- minimum pressure loss of the PROTEGO® flame arrester unit
- flameproof condensate drain
- maintenance-friendly design
- modular design enables replacement of individual FLAMEFILTER® discs and valve pallet

Pressure settings:

+3.5 mbar up to +210 mbar
 +1.4 inch W.C. up to +84 inch W.C.
 Higher pressure settings upon request.

Function and Description

The deflagration-proof and endurance burning-proof P/EB-E type PROTEGO® valve is a highly developed pressure relief valve for large flows with an integrated flame arrester unit that is specifically designed for use in ethanol production, processing, and storage. It is primarily used as a safety device for flame transmission-proof out-breathing on tanks, containers, and process equipment. The valve offers reliable protection against overpressure and prevents product losses almost up to the set pressure, while at the same time protecting against atmospheric deflagration and endurance burning if stabilized burning occurs. The PROTEGO® flame arrester unit is designed to achieve minimum pressure drop with maximum safety. The P/EB-E valve is available for substances of explosion group IIB1 (MESG ≥ 0.85 mm) and provides specific protection against deflagration and endurance burning of alcohol/air mixtures (such as ethanol/air).

The valve functions proportional, so the set pressures should be selected in relation to the proportional behavior (such as a 10%, 40%, or 100% overpressure from the set pressure to the relieving pressure at which the required flow performance is reached). The tank pressure is maintained up to the set pressure with a tightness that is far above the usual standards due to our state-of-the-art manufacturing. This feature is ensured by the valve seats made of high quality stainless steel



Demonstration of endurance burning
Video

Design Types and Specifications

The valve pallet is weight-loaded. At set pressures >80 mbar (32.1 inch W.C.), an extended design is used.

There are two different designs:

Pressure relief valve, basic design **P/EB - E -**

Pressure relief valve with heating jacket **P/EB - E -**
(max. heating fluid temperature +85°C / 185°F)

Additional special devices available upon request.

Table 1: Dimensions

Dimensions in mm / inches

To select the nominal size (DN), please use the flow capacity chart on the following page.

DN	50 / 2"	50 / 2"	80 / 3"	80 / 3"
Set pressure	≤ +80 mbar ≤ +32.1 inch W.C.	> +80 mbar > +32.1 inch W.C.	≤ +80 mbar ≤ +32.1 inch W.C.	> +80 mbar > +32.1 inch W.C.
a	218 / 8.58	218 / 8.58	218 / 8.58	218 / 8.58
b	288 / 11.34	453 / 17.83	290 / 11.42	455 / 17.91

Dimensions for pressure relief valve with heating jacket upon request.

Table 2: Selection of explosion group

MESG	Expl. Gr. (IEC/CEN)	Gas Group (NEC)	
≥ 0,85 mm	IIB1	–	Special approvals upon request.

Table 3: Material selection for housing

Design	B	C	
Housing	Steel	Stainless Steel	Special materials upon request.
Heating jacket (P/EB-E-H-...)	Steel	Stainless Steel	
Valve seat	Stainless Steel	Stainless Steel	
Weather hood	Steel	Stainless Steel	

Table 4: Material combination of flame arrester unit

Design	A	
FLAMEFILTER® casing	Stainless Steel	Special materials upon request.
FLAMEFILTER®	Stainless Steel	
Spacer	Stainless Steel	

Table 5: Material selection for valve pallet

Design	A	B	C	D	
Pressure range (mbar) (inch W.C.)	+3.5 up to +5.0 +1.4 up to +2.0	>+5.0 up to +14 >+2.0 up to +5.6	>+14 up to +210 >+5.6 up to +84	>+14 up to +210 >+5.6 up to +84	Special materials and higher pressure settings upon request.
Valve pallet	Aluminum	Stainless Steel	Stainless Steel	Stainless Steel	
Sealing	FEP	FEP	Metal to Metal	PTFE	

Table 6: Flange connection type

EN 1092-1; Form B1	Other types upon request.
ASME B16.5 CL 150 R.F.	



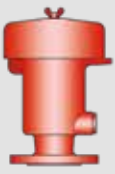

Pressure Relief Valve

Flow Capacity Chart

PROTEGO® P/EB-E

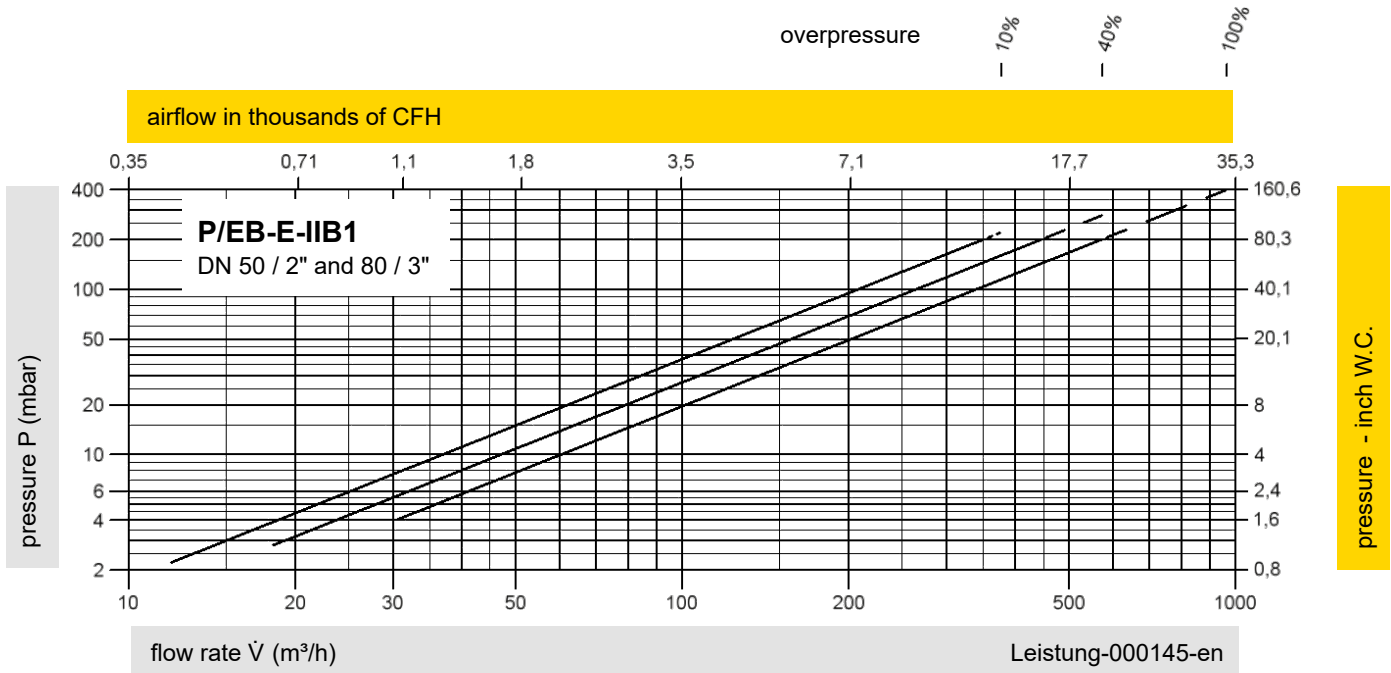

Remark

$$\text{set pressure} = \frac{\text{opening pressure resp. tank design pressure}}{1 + \frac{\text{overpressure \%}}{100\%}}$$

Set pressure = the valve starts to open

Opening pressure = set pressure plus overpressure

Overpressure % = percentage pressure increase over the set pressure

The flow capacity charts have been determined with a calibrated and TÜV certified flow capacity test rig. Volume flow \dot{V} in (m³/h) and CFH refer to the standard reference conditions of air in ISO 6358 (20°C, 1bar). For conversion to other densities and temperatures, refer to Sec. 1: "Technical Fundamentals."