

# In-Line Liquid Detonation Flame Arrester

for filling and drain lines - external installation



LDA-WF(W)

## PROTEGO® LDA-WF(W)

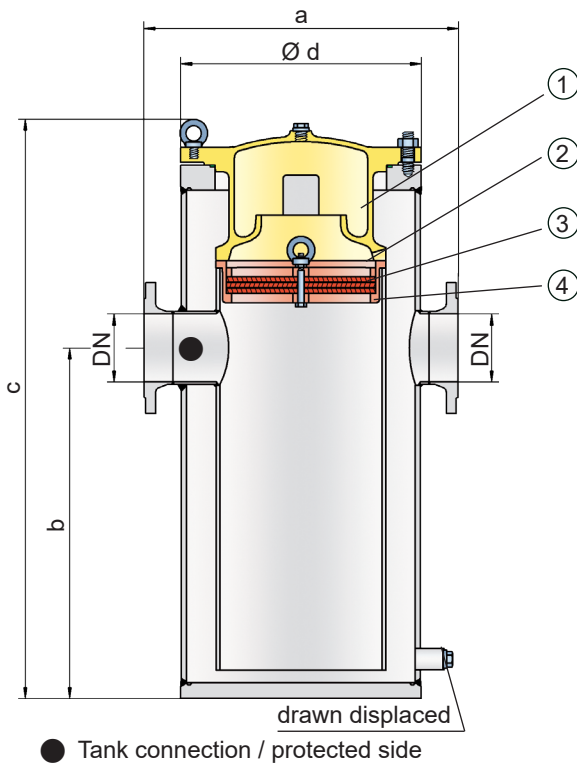

### Function and Description

The PROTEGO® LDA-WF(W) series of liquid detonation flame arresters was developed for storage container filling lines that are not continuously filled with product and sometimes contain a combustible mixture. The integrated siphon protection (1) with PROTEGO® flame arrester unit (2) additionally prevents the liquid, in which the lines are immersed, from being siphoned off while the container is being drained. The PROTEGO® flame arrester unit consists of several FLAMEFILTER® discs (3) and spacers firmly held in a FLAMEFILTER® cage (4). The number of FLAMEFILTER® discs and their gap size depends on the arrester's intended use. The device is installed outside the container in the filling and drain lines. If the explosive atmosphere

is ignited, the device prevents the combustion from traveling into the tank. The PROTEGO® LDA-WF(W) series of liquid detonation flame arresters combines the classic PROTEGO® flame arrester design with the siphon principle in which the liquid product serves as a barrier to flame propagation.

When a highly accelerated pipe deflagration or detonation occurs, the combustion pressure and flame propagation speed are substantially reduced, converted into a low-energy deflagration, and then stopped by the remaining immersion liquid and the PROTEGO® flame arrester.

The application range for the device is a product vapor/air mixture temperature of up to +60°C / 140°F and an absolute pressure up to 1.1 bar / 15.9 psi. **Devices with special approval for higher temperatures are available upon request.** This covers all possible operating conditions of empty lines for flammable liquids. The liquid detonation arrester is designed for pressures of up to 10 bar / 145 psi, resists explosion pressure, and provides protection for almost all flammable liquids. The device is approved for explosion groups IIA to IIB3 (NEC group D to C MESH ≥ 0.65 mm). **Special designs with a cleaning cover for highly viscous liquids can be provided.**

Type-approved in accordance with the current ATEX Directive and EN ISO 16852, as well as other international standards

### Special Features and Advantages

- easily accessible due to external installation
- siphon protection offers increased safety
- low risk of contamination
- low pressure loss
- provides protection against deflagrations and stable detonations
- useable for nearly all flammable liquids
- meets TRbF\* requirements

\*TRbF = technical regulations for flammable liquids

**Table 1: Dimensions**

Dimensions in mm / inches

To select the nominal size (DN), please use the flow capacity chart on the following pages.

DN	25 1"	32 1 1/4"	40 1 1/2"	50 2"	65 2 1/2"	80 3"	100 4"	125 5"	150 6"	200 8"	250 10"
a	250 / 9.84	250 / 9.84	346 / 13.62	350 / 13.78	446 / 17.56	450 / 17.72	500 / 19.69	600 / 23.62	600 / 23.62	700 / 27.56	900 / 35.43
b	325 / 12.80	325 / 12.80	415 / 16.34	415 / 16.34	535 / 21.06	535 / 21.06	600 / 23.62	915 / 36.02	915 / 36.02	1090 / 42.91	1300 / 51.18
c	475 / 18.70	475 / 18.70	605 / 23.82	605 / 23.82	831 / 32.72	831 / 32.72	936 / 36.58	1340 / 52.76	1340 / 52.76	1520 / 59.84	1750 / 68.90
d	150 / 5.91	150 / 5.91	210 / 8.27	210 / 8.27	275 / 10.83	275 / 10.83	325 / 12.80	460 / 18.11	460 / 18.11	510 / 20.08	610 / 24.02

**Table 2: Selection of the explosion group**

MESH	Expl. Gr. (IEC/CEN)	Gas Group (NEC)	Special approvals upon request.
≥ 0,65 mm	IIB3	C	



Stabilized FLAMEFILTER®  
Discs (Flyer pdf)

**Table 3: Specification of max. operating temperature**

≤ 60°C / 140°F	Tmaximum allowable operating temperature in °C	Higher operating temperatures upon request.
-	Classification	

**Table 4: Material selection for housing**

Design	A	B	Special materials upon request.
Housing	Steel	Stainless Steel	
Shock absorber	Steel	Stainless Steel	
Gasket (shock absorber)	FPM	PTFE	
Gasket (locking screw)	PTFE	PTFE	
Flame arrester unit	A	A	

**Table 5: Material for flame arrester unit**

Design	A	* The FLAMEFILTER® is also available in Tantalum, Inconel, Copper, etc., when the listed housing and cage materials are used. Special materials upon request.
FLAMEFILTER® cage	Stainless Steel	
FLAMEFILTER® *	Stainless Steel	
Spacer	Stainless Steel	

**Table 6: Flange connection type**

EN 1092-1; Form B1	Other types upon request.
ASME B16.5 CL 150 R.F.	

**Flow Capacity Chart**

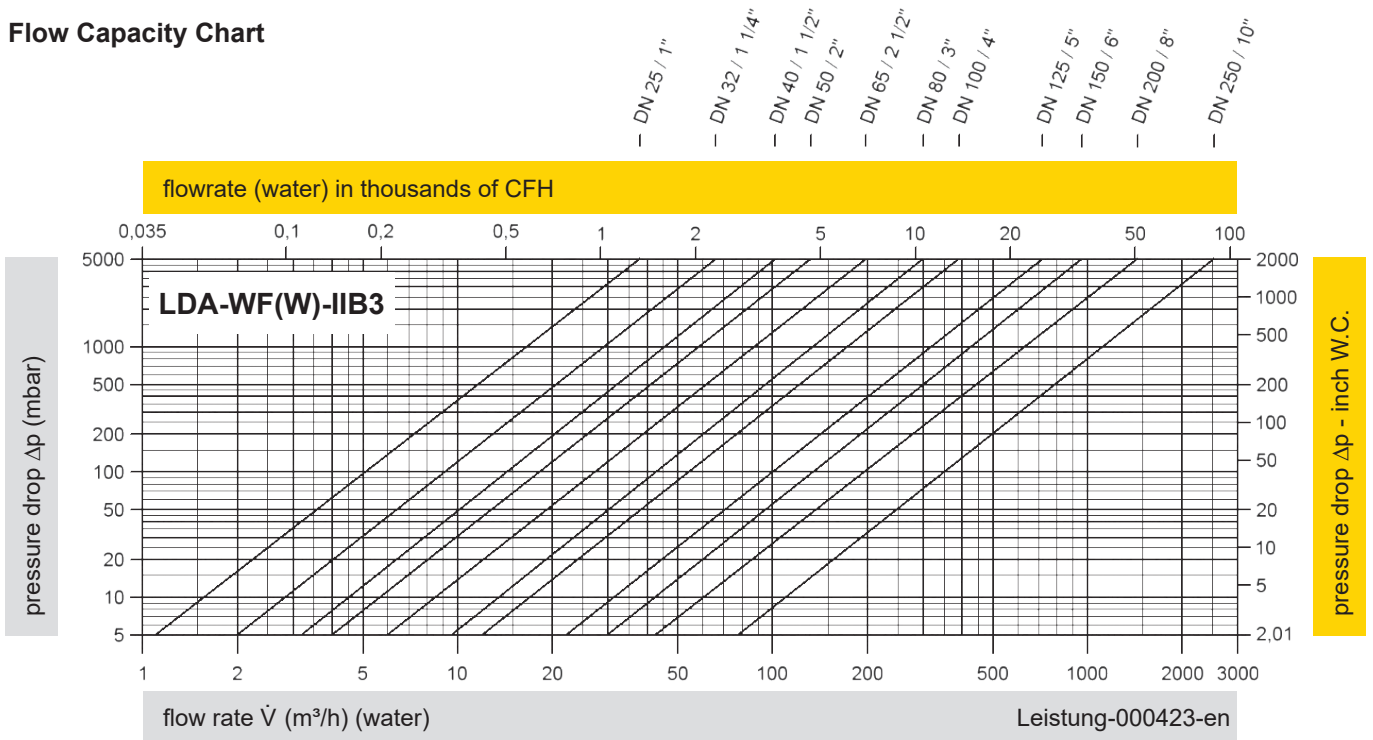

Conversion:  $\dot{V}_{water} = \dot{V}_{liquid} * \sqrt{\frac{\rho_{liquid}}{\rho_{water}}}$        $\dot{V}_{liquid} = \dot{V}_{water} * \sqrt{\frac{\rho_{water}}{\rho_{liquid}}}$

The volume flow  $\dot{V}$  in m³/h was determined with water, in accordance with DIN EN 60534, at a temperature  $T_n = 15^\circ\text{C}$  and an atmospheric pressure  $p_n = 1,013$  bar, kinematic viscosity  $\nu = 10^{-6}$  m²/s.

To avoid electrostatic charge of flammable liquids, the maximum flow is limited (refer to TRGS 727, CENELEC-Report CLC/TR 60079-32-1).

