

Emergency Pressure Relief Valve

PROTEGO® ER-V-LP

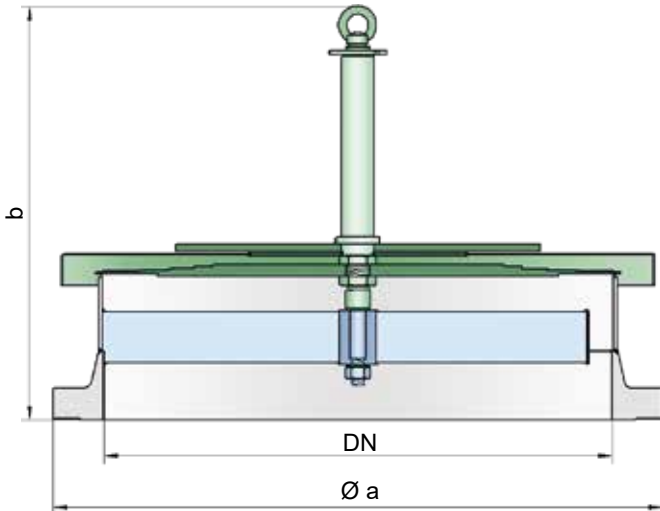

Pressure Settings:

+3.4 mbar up to +15 mbar
+1.4 inch W.C. up to +6 inch W.C.

For higher pressure settings, see types ER/V, ER/VH and ER/V-F.

Function and Description

The PROTEGO® type ER-V-LP valve is a sophisticated pressure relief valve for applications in which a high flow efficiency is of the essence. It is primarily used as an emergency pressure relief valve on storage tanks, vessels, silos, and process engineering equipment. It offers reliable protection against excessive overpressure and prevents excessive product loss at pressures as high as close to the set pressure. It is designed to release particularly large quantities to prevent the vessel from rupturing in an emergency case.

The valve will start to open as soon as the set pressure is reached and only requires a 10% pressure increase or opening pressure differential until full lift. Continuous investments in and a commitment to research and development have enabled PROTEGO® to develop a new *valve pallet technology* for which a patent has been granted. This patented *valve pallet technology* enables the typical safety valve characteristics to be applied to low pressure ranges while also maintaining a low leakage rate.

Adopting this new patented *valve pallet technology* permits the valve to be set to just 10% below the maximum allowable working pressure of the tank and still vent the required flow.

Due to the sophisticated manufacturing technology, the tank pressure is maintained up to the set pressure, with a tightness that is far above the common standards. Once the excess pressure is released, the valve re-seats and seals tight again.

Special Features and Advantages

- patented *valve pallet technology* guarantees excellent tightness resulting in the lowest possible product losses and reduced environmental impact
- 10% technology for minimum pressure increase until full lift
- set pressure close to opening pressure for optimum pressure maintenance in the system
- high flow efficiency
- valve pallet is guided inside the housing to protect against harsh weather conditions
- can be used in explosion hazardous areas
- sturdy housing design
- secured movable components
- best technology for API tanks

Design Types and Specifications

The valve pallet is weight-loaded. Higher set pressures are achieved with types ER/V and ER/VH (lever-operated) valves or Type ER/V-F (spring-loaded) valves.

Pressure valve in basic design

ER-V-LP

Additional special devices available upon request.



Emergency Relief Valve
(Flyer pdf)



Vents - 10% Technology
(Flyer pdf)

Table 1: Dimensions

Dimensions in mm / inches

To select the nominal size (DN), use the flow capacity chart on the following page.

DN	200 / 8"	250 / 10"	300 / 12"	350 / 14"	400 / 16"	450 / 18"	500 / 20"	600 / 24"	700 / 28"
a	343 / 13.50	406 / 15.98	483 / 19.02	533 / 20.98	597 / 23.50	635 / 25.00	699 / 27.52	813 / 32.01	837 / 32.95
b	378 / 14.88	399 / 15.71	409 / 16.10	440 / 17.32	455 / 17.91	464 / 18.27	481 / 18.94	556 / 21.89	571 / 22.48

Table 2: Material selection

Design	A	B	
Housing	Steel	Stainless Steel	Special materials upon request.
Valve seat	Stainless Steel	Stainless Steel	
Valve pallet	Stainless Steel	Stainless Steel	
Sealing	Stainless Steel	Stainless Steel	

Table 3: Flange connection type

EN 1092-1; Form B1	Other types upon request.
ASME B16.5 CL 150 R.F.	

Flow Capacity Chart

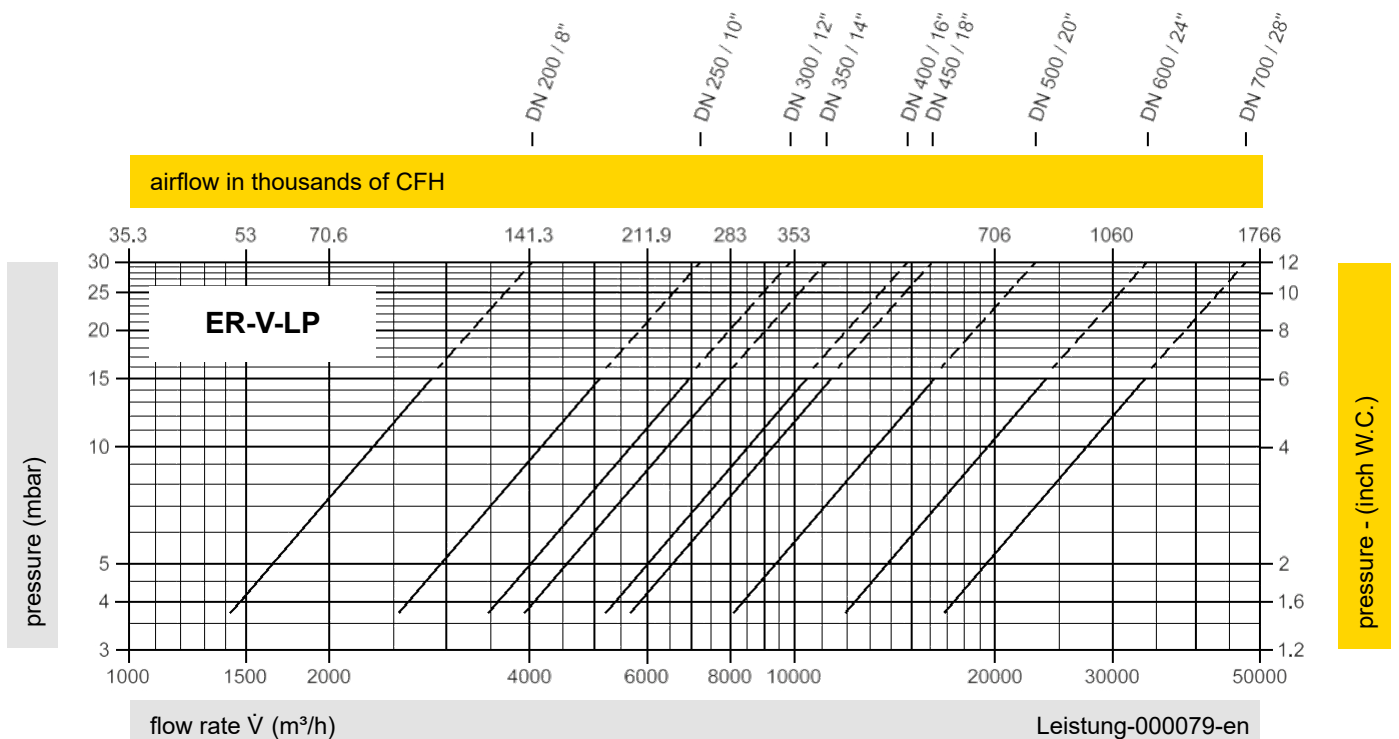

The flow capacity charts have been determined with a calibrated and TÜV certified flow capacity test rig. Volume flow \dot{V} in (m³/h) and CFH refer to the standard reference conditions of air in ISO 6358 (20°C, 1bar). For conversion to other densities and temperatures, refer to Sec. 1: "Technical Fundamentals."

