

Vent Valve, Lift-actuated

PROTEGO® AL/DK and PROTEGO® AL 200

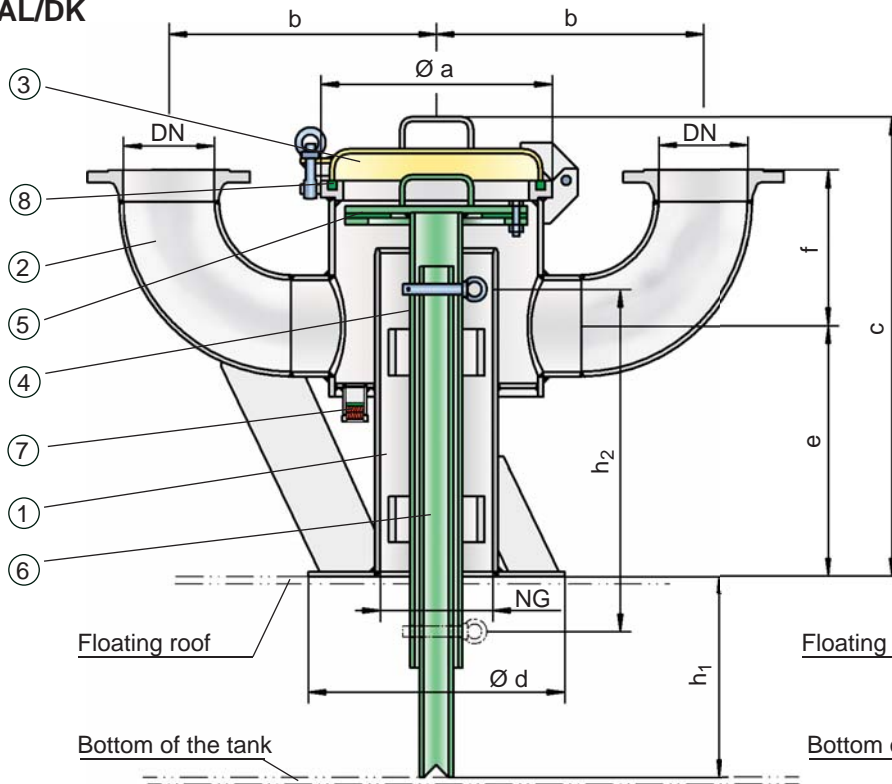

AL/DK



AL 200

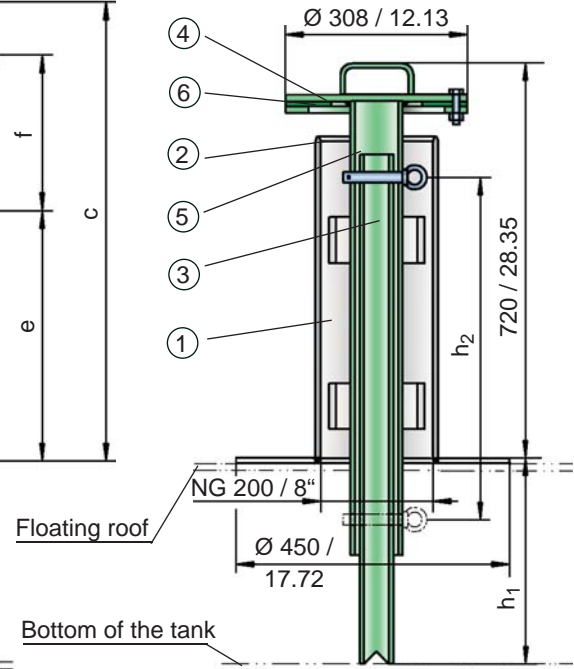

Dimensions in mm / inches

Function and Description

PROTEGO® lift-actuated vent valves type AL/DK provide automatic venting of floating roof tanks when the floating roof is lowered on its supports and the tank is either finally drained or refilled. When the floating roof is in its lowest position the valve is forced to open through lift actuation and this prevents unacceptable vacuum during final draining or unacceptable pressure during refilling.

In general the device consists of a housing (1) with sheet-metal panel to be welded on the floating roof, two or four connection nozzles (2) for installation of vent caps, cover (3), lift (4) including valve pallet (5), lift pipe (6) and the condensate drain valve (7) which can be flame transmission proof if required. A flat gasket is attached to the valve pallet (5) to provide sealing. The cover (3) is sealed by a sealing cord (8).

In general the device PROTEGO® AL 200 consists of a housing (1) with sheet-metal panel to be welded on the floating roof as well as the valve seat (2), lift (3) including valve pallet (4) and lift pipe (5). A flat gasket (6) which provides sealing.

As the lowest position of the floating roof varies for operation and assembly specify the dimensions h_1 and h_2 :

h_1 : Distance between lower edge of sheet-metal panel (or mounting flange) and tank bottom in lowest position of floating roof (operating position with an empty tank).

h_2 : Distance between floating roof in lifted maintenance position and height of floating roof in fully lowered operating position, if the tank is empty.

If the floating roof supports are changed from operating position to maintenance position the lift has to be lengthened as well. This is done with an adjustable locking pin that is secured with a bolt.

The valve is not flame transmission proof.

A hazard analysis (which considers the material selection and function of the device) shows that the device doesn't have any potential sources of ignition. Therefore they are not subject to the European Explosion Protection Directive (ATEX) when used in explosive atmosphere.

Designs and Specifications

Table 1: Dimensions for AL/DK

NG	200 / 8"	200 / 8"	200 / 8"	200 / 8"
DN	80 / 3"	100 / 4"	150 / 6"	200 / 8"
a	350 / 13.78	350 / 13.78	350 / 13.78	350 / 13.78
b	465 / 18.31	465 / 18.31	465 / 18.31	515 / 20.28
c	870 / 34.25	870 / 34.25	870 / 34.25	870 / 34.25
d	450 / 17.72	450 / 17.72	450 / 17.72	450 / 17.72
e	345 / 13.58	360 / 14.17	385 / 15.16	415 / 16.34
f	460 / 18.11	445 / 17.52	285 / 11.22	370 / 14.57

Dimensions in mm / inches

Table 2: Material

Housing	Steel	special materials upon request
Valve guide	Stainless Steel	
Gasket	FPM	

Table 3: Flange connection type DN

EN 1092-1, Form B1	other types upon request
ASME B16.5; 150 lbs RFSF	

Selection and Design

The required quantity and nominal size DN will be defined based on the calculated flow rate from the thermal venting and pump rate in lowest floating roof position (Nm³/h or CFH) and based on the maximum acceptable tank pressure p_T (mbar / inch W.C.) according to the flow capacity charts. Special models are available on request.

Flow rates and pressure losses of vent caps PROTEGO® EB or PROTEGO® LH/AD have additionally to be taken into account according to the appropriate charts in the relevant data sheets. Lift-actuated vent valves PROTEGO® AL 200 can be applied in case just venting is required.

Necessary Data for Specification

Stored product

Tank diameter (m or ft)

Tank height (m or ft)

Support height h₁ (operating position with empty tank)

Support height h₂ (lifted assembly position)

Maximum allowable tank pressure p_T (mbar or inch W.C.)

Pump rate (m³/h or CFH)

Application Examples for PROTEGO® AL/DK

Lift-actuated vent valves of type PROTEGO® AL/DK can be combined with vent caps type EB which are deflagration proof and resistant against endurance burning. This ensures flame transmission proof ventilation.

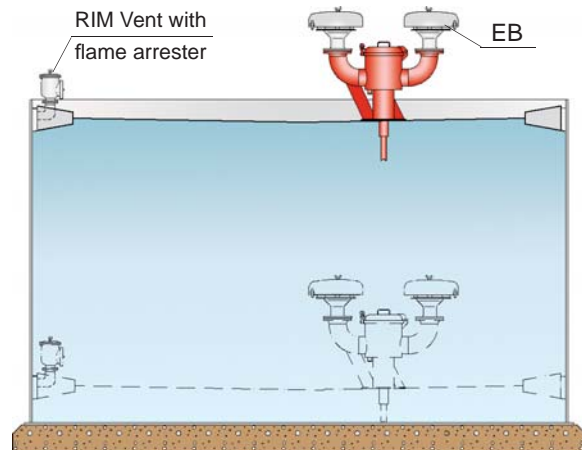

If resistance against endurance burning is not required the valves can alternatively be combined with PROTEGO® deflagration proof devices type PROTEGO® LH/AD. The applicable data sheets are available in volume 2 "Deflagration Flame Arresters, end-of-line and Vent Caps".

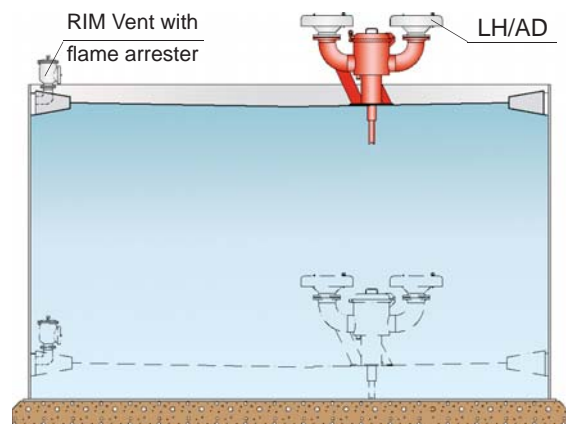

Application Examples for PROTEGO® AL 200

PROTEGO® AL 200 for fixed roof storage tanks with internal floating roof.

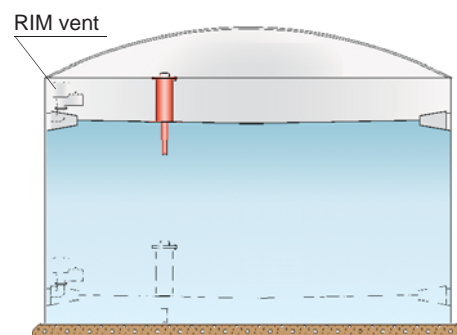

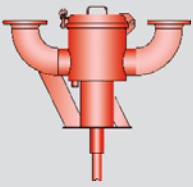

Vent Valve, Lift-actuated
Flow Capacity Charts

PROTEGO® AL/DK and PROTEGO® AL 200

DN 200 - 100 / 8" - 4"
 DN 200 - 150 / 8" - 6"
 DN 200 - 200 / 8" - 8"

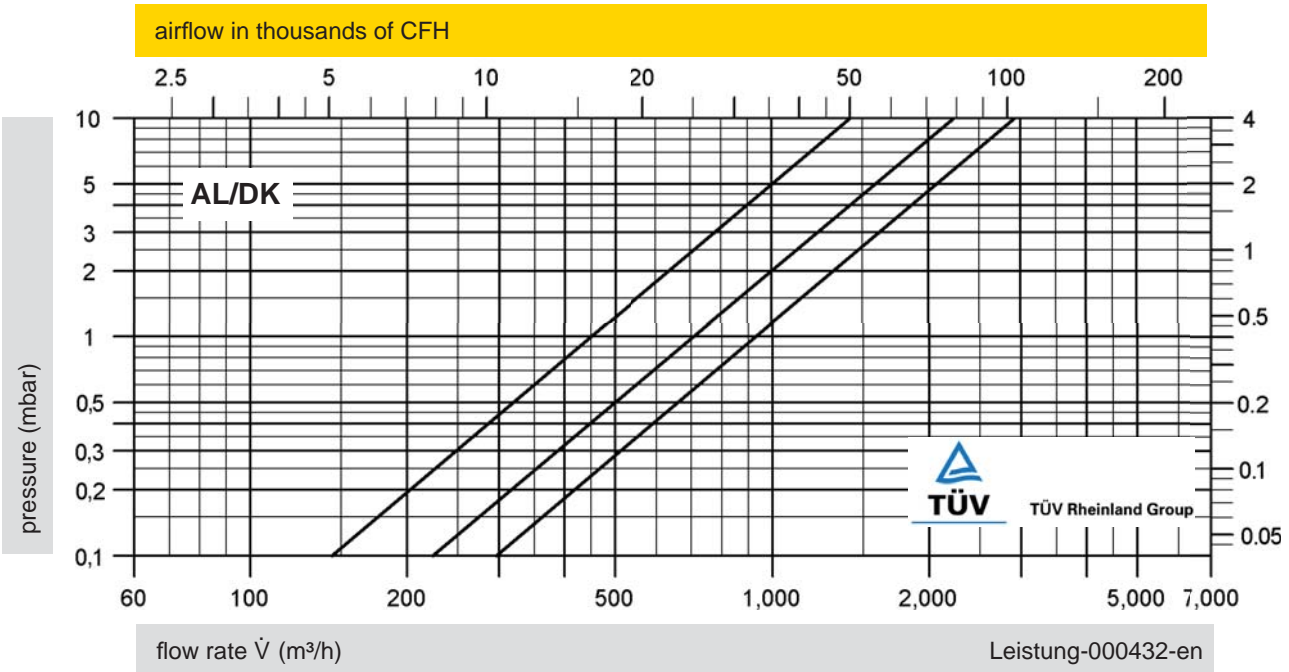

pressure - inch W.C.

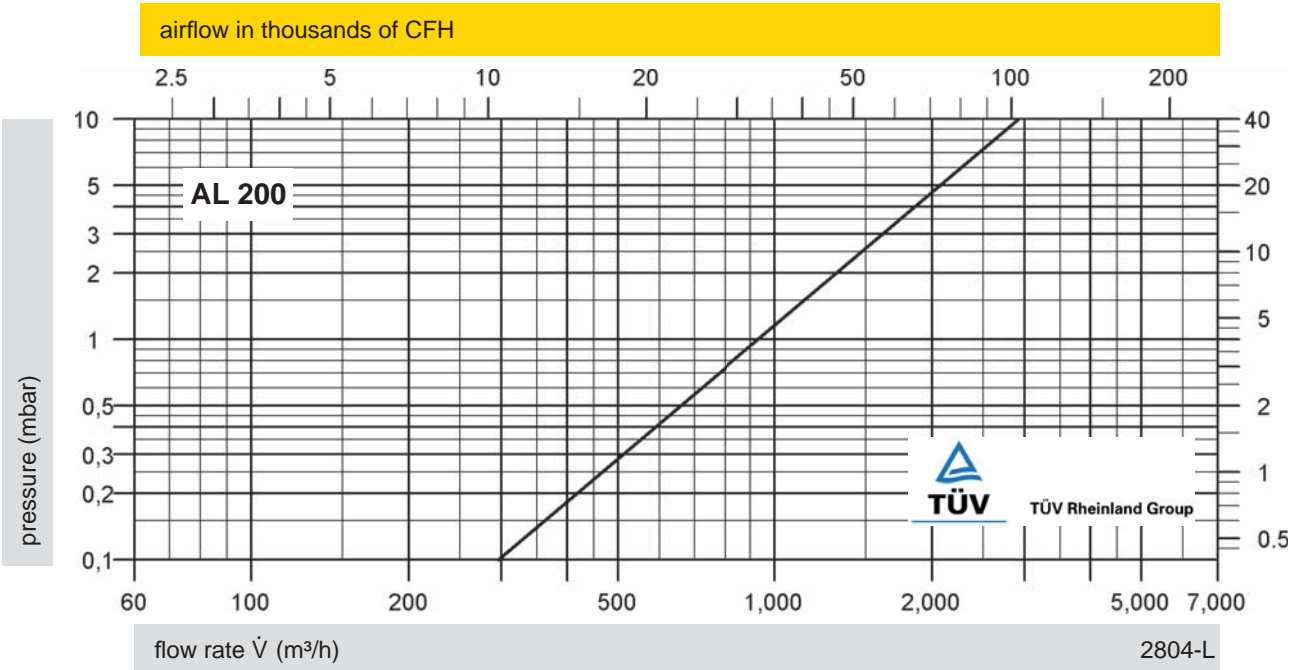

pressure - inch W.C.

The flow capacity charts have been determined with a calibrated and TÜV certified flow capacity test rig. Volume flow \dot{V} in (m³/h) and CFH refer to the standard reference conditions of air ISO 6358 (20°C, 1bar). Conversion to other densities and temperatures refer to Vol. 1: "Technical Fundamentals".